

## Industrial Pipe Sealant - ITPS#2

## Technical Data Sheet

**GENERAL INFORMATION:** *SAF-T-LOK* anaerobic adhesive/sealants are a specialized series of single component, solvent free compounds that are individually formulated for locking, sealing, retaining and bonding metal parts and assemblies. Stable in the presence of air, this product lubricates the assembly of parts then cures between the two mating metal parts, forming a resilient, vibration-proof polymer shim. *SAF-T-LOK* adhesive/sealants provide the user with additional performance characteristics, including resistance to corrosive chemicals or galvanic attack between dissimilar metals, as well as solvent resistance; while allowing disassembly with normal tools, if required.

**PRODUCT DESCRIPTION:** *SAF-T-LOK I-TPS#2* performs on all metals including Stainless Steel and Aluminum. *SAF-T-LOK I-TPS#2* was developed for NPT pipe connections but also performs on straight non-jamming threads. This pipe sealant begins curing immediately and is fully cured in 4 hours. After 8 hours sealing pressure exceeds the burst strength rating of the pipe. Pipes larger than 1 inch in diameter require more than 4 hours due to the larger gaps present in coarse pipe threads. *SAF-T-LOK I-TPS#2* does not attack paint.

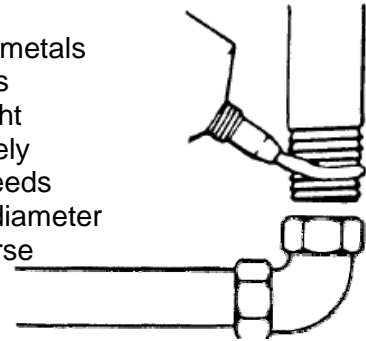

### PRODUCT CHARACTERISTICS: (Paste)

<b>Color</b>	<b>White</b>
<b>Specific Gravity</b>	<b>1.10 gm/cc</b>
<b>Particle Size</b>	<b>40 Micron</b>
<b>Viscosity</b>	<b>1,000,000 cps</b>
<b>Flash Point</b>	<b>860° F</b>
<b>Temperature Range</b>	<b>-65°F to +400°F</b>
<b>Storage Stability</b>	<b>+ 12 Months at &lt;75°F</b>

### PERFORMANCE CHARACTERISTICS: (Cured)

<b>Cure Speeds</b>	
<b>50% Cure</b>	<b>4 Hours</b>
<b>90% Cure</b>	<b>8 Hours</b>
<b>Locking Torque</b>	<b>500 in. lbs. (1/2 in. NPT pipe)</b>
<b>Instant Sealing</b>	<b>&gt;200 psig</b>
<b>Chemical Resistance</b>	<b>Excellent</b>

*SAF-T-LOK I-TPS#2* pipe sealant provides instant seal, but also allows 30 minutes for readjustment of assemblies. *SAF-T-LOK I-TPS#2* is rated by UL. Fire hazard is small. No flash point in the liquid state. Ignition temperature 860°F.

**IMPORTANT NOTICE:** All statements and technical data contained herein are based on tests we believe to be reliable, but the accuracy of completeness thereof is not guaranteed. It is recommended that the buyer test this product to determine its suitability for his application before use. **SAF-T-LOK International Corporation** is not responsible for loss, claim or damages resulting from use of its products.